

**STULZ**

CLIMATE. CUSTOMIZED.



# Mini-Space EC

**DX and CW**  
**4 – 12 kW Systems**  
Vertical Floor Mounted, 60 Hz Data

**Engineering Manual**



### **ABOUT STULZ**

STULZ is a privately owned, global manufacturer of highly efficient temperature and humidity management technology. STULZ engineers a full line of air conditioners, air handlers, ultrasonic humidifiers, desiccant dehumidifiers and custom solutions, specifically for industrial, commercial and secure mission-critical applications.

### **GLOBAL LEADER**

From our beginnings in Germany 70 years ago to our expansion throughout the world, STULZ is always innovating.

Today, STULZ has seven global production plants, and hundreds of sales and service partners around the world.

### **MADE IN THE USA**

STULZ believes that every region of the world has specific mission critical cooling needs. This is why STULZ Air Technology Systems, Inc. (STULZ USA) is proud to research, design, manufacture, test and support our solutions in Frederick, MD.

To STULZ, this is what “Made in America” means.



# Table of Contents

## Model Nomenclature Guide

### Specifications ..... 1

### Product Features Index ..... 2

### DX Technical Specifications ..... 3

Air Cooled ..... 3

Water Cooled ..... 4

Glycol Cooled ..... 5

### DX Performance/Capacity Data ..... 6

### CW Tech Specs/Performance ..... 7

Technical Specifications ..... 7

Performance Data - 50 °F EWT ..... 8

Performance Data - 45 °F EWT ..... 8

### Electrical Data ..... 10

Electrical Data - DX Systems / With Condensate Pump ..... 10

Electrical Data - DX Systems / Without Condensate Pump ..... 11

Electrical Data - Chilled Water Systems / With and Without Condensate Pump ..... 12

### Dimensional Data ..... 13

CCU/CCR-041/061/081/121-A, W, G-EC, & -110-C-EC ..... 13

CCD/CCF-041/061/081/121-A, W, G-EC & -110-C-EC ..... 14

### Product Guide Specifications ..... 15

SUMMARY ..... 15

DESIGN REQUIREMENTS ..... 15

QUALITY ASSURANCE ..... 15

CABINET ..... 15

Air Flow Patterns ..... 15

Up-Flow: ..... 15

Down-Flow: ..... 15

Air Filtration ..... 15

MECHANICAL COMPONENTS ..... 15

Blower ..... 15

Backward Inclined, Plenum Style Fan, with an EC Motor ..... 15

DX Refrigeration System ..... 15

Scroll Compressor ..... 16

Evaporator Coil ..... 16

Snap-Acting Hot Gas Bypass (Optional) ..... 16

Air-Cooled Heat Rejection ..... 16

Water/Glycol Cooled Heat Rejection ..... 16

Chilled Water ..... 16

Cooling Coil ..... 16

CW Control Valves ..... 16

Steam Generating Humidifier (Standard) ..... 16

Dehumidification Cycle (Standard) ..... 16

REHEAT ..... 16

Electric Heat/ Reheat (Standard) ..... 16

Hot Water/Steam Reheat/Heat (Optional) ..... 16

Hot Gas Reheat (Optional) ..... 17

ELECTRICAL SYSTEM ..... 17

Main Power Service Switch ..... 17

Remote Stop/Start Contacts ..... 17

AIR CONTROL ..... 17

EC Fan Speed Control ..... 17

*E*<sup>2</sup>SERIES CONTROLLER

DESCRIPTION ..... 17

General ..... 17

Field Configurable ..... 17

Password Protection ..... 17

Restorable Parameters/Factory Defaults ..... 17

Timer Feature ..... 18

A/C Grouping pLAN Operation ..... 18

BMS Interface (Optional) ..... 18

Alarms ..... 18

Controller Graphic Terminal ..... 18

OPTIONAL FEATURES ..... 18

Adjustable Floor Stand ..... 18

Top Discharge Plenum Box (Up-flow units only) ..... 18

Condensate Pump ..... 18

Smoke Detection ..... 18

Firestat ..... 18

Remote Water Detector- Spot Type ..... 18

Remote Water Detector- Strip Type ..... 19

Low Entering Condenser Water Kit ..... 19

CODE CONFORMANCE ..... 19

## Model Nomenclature

### CCX-XXX-X-EC

CC	Air Pattern	Capacity (kW)	Refrigerant Circuits	Cooling Method	Blower Type
Mini-Space Compact System	D=Downflow	04	0	A=Air	EC
	U=Upflow	06	1	W=Water	
	R=Rear Return	08		G=Glycol	
	F=Front Discharge	11		C=Chilled Water	
		12			

Example:

12 kW capacity, downflow air pattern, 1 circuit, water-cooled DX, EC fans: CCD-121-W-EC

**Model Nomenclature  
Guide Specifications**

**DX - EVAPORATOR SECTIONS**

**Air Cooled Remote Evaporator  
(Models CC( )-( )-A-EC)**

The system shall be a remote (split) air cooled, floor mounted precision air conditioner evaporator. The evaporator section shall house, as a minimum, the evaporator coil, expansion valve, return air filter, compressor, evaporator blower/motor and associated electrical and refrigeration components.

The CC( )-( )-A-EC evaporator section shall be located at some distance from its corresponding STULZ model SCS-( )-( ) outdoor air cooled condenser.

The evaporator system shall require only a single point main power supply connection; and the system shall ship from the STULZ factory with a dry nitrogen holding charge ready for field refrigerant (R410A) charging.

**DX - WATER COOLED SYSTEMS**

**Integral Self-Contained  
(Models CC( )-( )-W-EC)**

The system shall be a self-contained, floor mounted precision air conditioner to include integral water cooled, plate-fin condenser with factory installed head pressure water regulating control valve(s). Condenser (source) water shall be provided by a cooling tower or some other remote water source.

The system shall require only single point supply power connection and shall ship from the STULZ factory with a full operating refrigerant (R410A) charge.

**Water Regulating Valves**

Head pressure shall be automatically controlled by a factory installed 2-way water regulating valve rated for 600 psig wwp.

A 3-way valve is optionally available.

**DX - GLYCOL COOLED SYSTEMS**

**Integral Self-Contained  
(Models CC( )-( )-G-EC)**

The system shall be a self-contained, floor mounted precision air conditioner to include integral glycol cooled, plate-fin condenser with factory installed head pressure glycol regulating control valve(s). Condenser (source) glycol solution shall be provided via a STULZ remote glycol pump package and dry-cooler system.

The system shall require only a single point supply power connection and shall ship from the STULZ factory with a full operating refrigerant (R410A) charge.

**Glycol Regulating Valves**

Head pressure shall be automatically controlled by a factory installed, 2-way glycol regulating valve rated for 600 psig wwp.

A 3-way valve is optionally available.

**CHILLED WATER AIR HANDLERS**

**Chilled Water System  
(Models CC( )-( )-C-EC)**

The system shall be a floor mounted, chilled water precision air conditioner to include chilled water cooling coil, evaporator blower and motor and chilled water control valve. Chilled water shall be provided by a remote liquid chiller system.

**Chilled Water Control Valve**

Cooling capacity shall be controlled with a factory installed 3-way modulating control valve rated for 600 psig. A 2-way valve rated at 600 psig is optionally available.

<b>Mini-Space EC Model</b>	<b>041/061/081</b>	<b>110</b>	<b>121</b>
<b>SELECTED STANDARD FEATURES:</b>			
<b>TEMPERATURE CONTROL</b>			
1-Stage Cooling Mode	Standard	Standard	Standard
1-Stage Electric Reheating / Heating	Standard	Standard	Optional
2-Stage Electric Reheating / Heating	N/A	N/A	N/A
Cooling and/or Heating Only (No Humidity Control)	Optional	Optional	Optional
<b>HUMIDITY CONTROL</b>			
Electrode Canister Steam Humidifier	Standard	Standard	Standard
Dehumidification Mode Electric Reheat	Standard	Standard	Standard
<b>CONTROLS</b>			
E <sup>2</sup> Advanced Microprocessor w/ Alarms	Standard	Standard	Standard
<b>CABINET</b>			
Galvannealed Steel, Powder Coated Finish	Standard	Standard	Standard
Insulated Stainless Steel Condensate Drain Pan	Standard	Standard	Standard
2 lb/ft <sup>2</sup> Density Thermal & Sound Insulation	Standard	Standard	Standard
Floor Stand (Adjustable)	Optional	Optional	Optional
<b>FILTERS / PLENUMS</b>			
2", 30% Avg. Eff. Pleated Filters	Standard	Standard	Standard
2", 60% Avg. Eff. Pleated Filters	Optional	Optional	Optional
2- or 3-way Plenum Box (Up-Flow Units)	Optional	Optional	Optional
<b>DX-REFRIGERATION CIRCUIT</b>			
R410A Refrigerant	Standard	N/A	Standard
Scroll Compressors	Standard	N/A	Standard
Rotolock Service Valves	Standard	N/A	Standard
High Efficiency, Aluminum Fin / Copper Tube Coils	Standard	N/A	Standard
Thermal Expansion Valves	Standard	N/A	Standard
Refrigerant Sight Glasses & Filter/Drier Strainers	Standard	N/A	Standard
<b>BLOWERS / MOTORS</b>			
Backward Curved Direct Driven EC	Standard	Standard	Standard
<b>ELECTRICAL</b>			
1- or 3-phase Power Supply	----- See Electrical Tables Section -----		
Multi-Voltage Control Transformer (24V Class 2)	Standard	Standard	Standard
<b>SAFETY FEATURES</b>			
E <sup>2</sup> Visual Local & Remote Alarms	Standard	Standard	Standard
Main Power Non-Fused Disconnect, unit mounted	Standard	Standard	Standard
High / Low Refrigerant Pressure Switches (DX units)	Standard	Standard	Standard
Motor Overload Protection	Standard	Standard	Standard
<b>SPECIFIC MODEL STANDARD FEATURES:</b>			
<b>AIR COOLED</b>			
Low Ambient Head Pressure Control	-----Two types: -20 °F or -30 °F*-----		
Remote Air Cooled Condenser	Standard	N/A	Standard
<b>WATER / GLYCOL COOLED</b>			
2-way, 600 psig Water/Glycol Regulating Valves	Standard	N/A	Standard
3-way, 600 psig Water/Glycol Regulating Valves	Optional	N/A	Optional
Stainless Steel Brazed Plate Heat Exchanger	Standard	N/A	Standard
<b>CHILLED WATER SYSTEMS (CC()-110-CW)</b>			
3-way, 600 psig Modulating Valve	N/A	Standard	N/A
2-way, 600 psig Modulating Valve	N/A	Optional	N/A

\*Flooded head pressure control not available on all models.

Model:	CC()-041-A-EC	CC()-061-A-EC	CC()-081-A-EC	CC()-121-A-EC
<b>Evaporator Blower / Motor - Backward Curved EC</b>				
Nominal Motor Power, hp	1.3	1.3	1.3	1.3
Rated Air Flow, ft <sup>3</sup> /min @ 0.2 inH <sub>2</sub> O esp	1,180	1,180	1,180	1,890
Quantity of Blowers	1	1	1	1
<b>Evaporator Coil - Aluminum Fin, Copper Tube</b>				
Rows (Face Area ft <sup>2</sup> )	4 (3.25)	4 (3.25)	4 (3.25)	4 (3.25)
Face Velocity, ft/min	363	363	363	581
<b>Compressor - R-410A</b>				
Type (Quantity)	Scroll (1)	Scroll (1)	Scroll (1)	Scroll (1)
Input per Compressor, W	1,880	2,230	2,850	3,760
Total Heat of Rejection, kW (MBH)	8.6 (29.3)	10.1 (34.4)	12.4 (42.3)	16.6 (56.5)
<b>Reheat/Heat - Performance Capacities Include Evaporator Blower Motor Heat</b>				
<b>Electric Reheat / Heat (Standard)</b>				
Number of Stages	1	1	1	1
Total Nominal Capacity, kW (MBH)	3 (10.2)	3 (10.2)	3 (10.2)	6 (20.5)
<b>Hot Gas Reheat (Optional)</b>				
Total Capacity, kW (MBH)	1.9 (6.4)	2.2 (7.6)	2.8 (9.7)	3.8 (12.8)
<b>Hot Water Reheat / Heat (Optional) - Reheat Rated @ 180 °F Entering Water Temperature, EAT = 72 °F DB</b>				
Total Capacity, kW (MBH)	9.2 (31.5)	9.2 (31.5)	18.6 (63.5)	18.6 (63.5)
Flow Rate gpm (Pressure Drop, ftH <sub>2</sub> O)	3.2 (.7)	3.2 (.7)	6.5 (.8)	6.5 (.8)
Control Valve	on/off	on/off	on/off	on/off
<b>Humidification (Standard) - Electrode Steam Canister Humidifier with Adjustable Output</b>				
Steam Output, lb/hr (Power Input, kW)	2-5 (1.7)	2-5 (1.7)	2-5 (1.7)	2-5 (1.7)
Std Control	Cycling	Cycling	Cycling	Cycling
<b>Filters (Standard) - Disposable, MERV 8 Average Dust Spot Efficiency</b>				
Up-flow, Front free return. Nom. Size (in.) (Quantity)	20 × 23 (1)	20 × 23 (1)	20 × 23 (1)	20 × 23 (1)
Up-flow, Rear-ducted return. Nom. Size (in.) (Quantity)	20 × 25 (1)	20 × 25 (1)	20 × 25 (1)	20 × 25 (1)
Down-flow. Nom. Size (in.) (Quantity)	20 × 23 (1)	20 × 23 (1)	20 × 23 (1)	20 × 23 (1)
<b>Connection Sizes - Copper (Please refer to Mini-Space EC IOM Manual for proper interconnecting refrigerant line sizing.)</b>				
Liquid Line, in. OD (one per unit)	1/2	1/2	1/2	1/2
Hot Gas Line, in. OD (one per unit)	5/8	5/8	5/8	5/8
Condensate Drain, in. OD	7/8	7/8	7/8	7/8
Humidifier Inlet, in. OD	1/4	1/4	1/4	1/4
<b>Physical Data</b>				
Approximate Unit Weight, lb	450	450	450	480
Unit Dimensions, H in. x W in. x D in. CCU/D/F-(-)A	73 × 25 × 24	73 × 25 × 24	73 × 25 × 24	73 × 25 × 24
Unit Dimensions, H in. x W in. x D in. CCR-(-)A	73 × 25 × 44	73 × 25 × 44	73 × 25 × 44	73 × 25 × 44
Shipping Dimensions, H in. x W in. x D in. CCU/D/F-(-)A	81 × 33 × 32	81 × 33 × 32	81 × 33 × 32	81 × 33 × 32
Shipping Dimensions, H in. x W in. x D in. CCR-(-)A	81 × 33 × 52	81 × 33 × 52	81 × 33 × 52	81 × 33 × 52

Model:	CC()-041-W-EC	CC()-061-W-EC	CC()-081-W-EC	CC()-121-W-EC
<b>Evaporator Blower / Motor - Backward Curved EC</b>				
Nominal Motor Power, hp	1.3	1.3	1.3	1.3
Rated Air Flow, ft <sup>3</sup> /min @ 0.2 inH <sub>2</sub> O esp	1,180	1,180	1,180	1,890
Quantity of Blowers	1	1	1	1
<b>Evaporator Coil - Aluminum Fin, Copper Tube</b>				
Rows (Face Area ft <sup>2</sup> )	4 (3.25)	4 (3.25)	4 (3.25)	4 (3.25)
Face Velocity, ft/min	363	363	363	581
<b>Compressor - R-410A</b>				
Type (Quantity)	Scroll (1)	Scroll (1)	Scroll (1)	Scroll (1)
Input per Compressor, W	1,510	1,810	2,580	3,020
<b>Water Cooled Condenser - Plate-Finned (Based on 0% Glycol Solution)</b>				
Total Heat of Rejection, kW (MBH)	8.9 (30.4)	10.3 (35.2)	12.6 (43.1)	17.3 (58.9)
Flow Rate, gpm @ 85 °F EWT / 95 °F LWT	6.1	7.1	8.7	11.8
Total Unit Pressure Drop (ftH <sub>2</sub> O)	5.0	5.8	6.6	5.7
<b>Reheat/Heat - Performance Capacities Include Evaporator Blower Motor Heat</b>				
<b>Electric Reheat / Heat (Standard)</b>				
Number of Stages	1	1	1	1
Total Nominal Capacity, kW (MBH)	3 (10.2)	3 (10.2)	3 (10.2)	6 (20.5)
<b>Hot Gas Reheat (Optional)</b>				
Total Capacity, kW (MBH)	1.4 (4.9)	1.7 (5.8)	2.2 (7.4)	2.9 (9.7)
<b>Hot Water Reheat / Heat (Optional) - Reheat Rated @ 180 °F Entering Water Temperature, EAT = 72 °F DB</b>				
Total Capacity, kW (MBH)	9.2 (31.5)	9.2 (31.5)	18.6 (63.5)	18.6 (63.5)
Flow Rate, gpm (Pressure Drop, ftH <sub>2</sub> O)	3.2 (.7)	3.2 (.7)	6.5 (.8)	6.5 (.8)
Control Valve	on/off	on/off	on/off	on/off
<b>Humidification (Standard) - Electrode Steam Canister Humidifier with Adjustable Output</b>				
Steam Output, lb/hr (Power Input, kW)	2-5 (1.7)	2-5 (1.7)	2-5 (1.7)	2-5 (1.7)
Std Control	Cycling	Cycling	Cycling	Cycling
<b>Filters (Standard) - Disposable, MERV 8 Average Dust Spot Efficiency</b>				
Up-flow, Front Free Return. Actual Size (in.) (Quantity)	20 × 23 (1)	20 × 23 (1)	20 × 23 (1)	20 × 23 (1)
Up-flow, Rear-ducted Return. Actual Size (in.) (Quantity)	20 × 25 (1)	20 × 25 (1)	20 × 25 (1)	20 × 25 (1)
Down-flow. Actual Size (in.) (Quantity)	20 × 23 (1)	20 × 23 (1)	20 × 23 (1)	20 × 23 (1)
<b>Connection Sizes - Copper (Please refer to Mini-Space EC IOM Manual for proper interconnecting refrigerant line sizing.)</b>				
Condensate Drain, in. OD	7/8	7/8	7/8	7/8
Humidifier Inlet, in. OD	1/4	1/4	1/4	1/4
Condenser In and Out, in. OD	7/8	7/8	7/8	7/8
<b>Physical Data</b>				
Approximate Unit Weight, lb	480	480	480	510
Unit Dimensions, H in. x W in. x D in. CCU/D/F-(-)A	73 × 25 × 24	73 × 25 × 24	73 × 25 × 24	73 × 25 × 24
Unit Dimensions, H in. x W in. x D in. CCR-(-)A	73 × 25 × 44	73 × 25 × 44	73 × 25 × 44	73 × 25 × 44
Shipping Dimensions, H in. x W in. x D in. CCU/D/F-(-)A	81 × 33 × 32	81 × 33 × 32	81 × 33 × 32	81 × 33 × 32
Shipping Dimensions, H in. x W in. x D in. CCR-(-)A	81 × 33 × 52	81 × 33 × 52	81 × 33 × 52	81 × 33 × 52



Model:	CC()-041-G-EC	CC()-061-G-EC	CC()-081-G-EC	CC()-121-G-EC
<b>Evaporator Blower / Motor - Backward Curved EC</b>				
Nominal Motor Power, hp	1.3	1.3	1.3	1.3
Rated Air Flow, ft <sup>3</sup> /min @ 0.2 inH <sub>2</sub> O esp	1,180	1,180	1,180	1,890
Quantity of Blowers	1	1	1	1
<b>Evaporator Coil - Aluminum Fin, Copper Tube</b>				
Rows (Face Area, ft <sup>2</sup> )	4 (3.25)	4 (3.25)	4 (3.25)	4 (3.25)
Face Velocity, ft/min	363	363	363	581
<b>Compressor - R-410A</b>				
Type (Quantity)	Scroll (1)	Scroll (1)	Scroll (1)	Scroll (1)
Input per Compressor, W	2,020	2,390	3,050	4,040
<b>Glycol Cooled Condenser - Plate-Finned (Based on 40% Ethylene Glycol Solution)</b>				
Total Heat of Rejection, kW (MBH)	8.5 (29.1)	10.1 (34.4)	12.2(41.7)	16.4 (56.1)
Flow Rate, gpm @ 85 °F EWT / 95 °F LWT	6.3	7.6	10.2	12.6
Unit Pressure Drop (ftH <sub>2</sub> O)	4.6	5.4	7.0	5.7
<b>Reheat/Heat - Performance Capacities Include Evaporator Blower Motor Heat</b>				
<b>Electric Reheat / Heat (Standard)</b>				
Number of Stages	1	1	1	1
Total Nominal Capacity, kW (MBH)	3 (10.2)	3 (10.2)	3 (10.2)	6 (20.5)
<b>Hot Gas Reheat (Optional)</b>				
Total Capacity, kW (MBH)	2.0 (6.9)	2.4 (8.2)	3.0 (10.4)	4.0 (14.0)
<b>Hot Water Reheat / Heat (Optional) - Reheat Rated @ 180 °F Entering Water Temperature, EAT = 72 °F DB</b>				
Total Capacity, kW (MBH)	9.2 (31.5)	9.2 (31.5)	18.6 (63.5)	18.6 (63.5)
Flow Rate, gpm (Pressure Drop, ftH <sub>2</sub> O)	3.2 (.7)	3.2 (.7)	6.5 (.8)	6.5 (.8)
Control Valve	on/off	on/off	on/off	on/off
<b>Humidification (Standard) - Electrode Steam Canister Humidifier with Adjustable Output</b>				
Steam Output, lb/hr (Power Input, kW)	2-5 (1.7)	2-5 (1.7)	2-5 (1.7)	2-5 (1.7)
Std Control	Cycling	Cycling	Cycling	Cycling
<b>Filters (Standard) - Disposable, MERV 8 Average Dust Spot Efficiency</b>				
Up-flow, Front Free Return. Actual Size (in.) (Quantity)	20 × 23 (1)	20 × 23 (1)	20 × 23 (1)	20 × 23 (1)
Up-flow, Rear-ducted Return. Actual Size (in.) (Quantity)	20 × 25 (1)	20 × 25 (1)	20 × 25 (1)	20 × 25 (1)
Down-flow. Actual Size (in.) (Quantity)	20 × 23 (1)	20 × 23 (1)	20 × 23 (1)	20 × 23 (1)
<b>Connection Sizes - Copper (Please refer to Mini-Space EC IOM Manual for proper interconnecting refrigerant line sizing.)</b>				
Condensate Drain, in. OD	7/8	7/8	7/8	7/8
Humidifier Inlet, in. OD	1/4	1/4	1/4	1/4
Condenser In and Out, in. OD	7/8	7/8	7/8	7/8
<b>Physical Data</b>				
Approximate Unit Weight, lb	480	480	480	510
Unit Dimensions, H in. x W in. x D in. CCU/D/F(-)-A	73 × 25 × 24	73 × 25 × 24	73 × 25 × 24	73 × 25 × 24
Unit Dimensions, H in. x W in. x D in. CCR(-)-A	73 × 25 × 44	73 × 25 × 44	73 × 25 × 44	73 × 25 × 44
Shipping Dimensions, H in. x W in. x D in. CCU/D/F(-)-A	81 × 33 × 32	81 × 33 × 32	81 × 33 × 32	81 × 33 × 32
Shipping Dimensions, H in. x W in. x D in. CCR(-)-A	81 × 33 × 52	81 × 33 × 52	81 × 33 × 52	81 × 33 × 52

Model:	CC()-041-A-EC	CC()-061-A-EC	CC()-081-A-EC	CC()-121-A-EC
<b>NET DX COOLING CAPACITY - (Includes Motor Heat @ Rated ft<sup>3</sup>/min &amp; esp)</b>				
<b>80 °F DB/62.9 °F WB, 38% RH, 52.3 °F DP</b>				
Total, kW (MBH)	6.8 (23.2)	7.7 (26.1)	9.3 (31.7)	12.4 (42.2)
Sensible, kW (MBH)	6.8 (23.2)	7.7 (26.1)	9.1 (31.2)	12.4 (42.2)
<b>75 °F DB/61.1 °F WB, 45% RH, 52.3 °F DP</b>				
Total, kW (MBH)	6.2 (21.2)	7.1 (24.1)	9.1 (31)	11.7 (39.8)
Sensible, kW (MBH)	6.2 (21.2)	7.1 (24.1)	8.2 (27.9)	11.4 (39.1)
<b>72 °F DB/60.0 °F WB, 50% RH, 52.3 °F DP</b>				
Total, kW (MBH)	6.2 (21.3)	7.2 (24.4)	8.7 (29.7)	11.6 (39.5)
Sensible, kW (MBH)	6.2 (21.3)	7.1 (24.2)	7.2 (24.4)	11.3 (38.5)

Model:	CC()-041-W-EC	CC()-061-W-EC	CC()-081-W-EC	CC()-121-W-EC
<b>NET DX COOLING CAPACITY - (Includes Motor Heat @ Rated ft<sup>3</sup>/min &amp; esp)</b>				
<b>80 °F DB/62.9 °F WB, 38% RH, 52.3 °F DP</b>				
Total, kW (MBH)	7.5 (25.6)	8.6 (29.3)	10.4 (35.5)	13.7 (46.8)
Sensible, kW (MBH)	7.5 (25.6)	8.6 (29.3)	9.5 (32.4)	13.7 (46.8)
<b>75 °F DB/61.1 °F WB, 45% RH, 52.3 °F DP</b>				
Total, kW (MBH)	6.9 (23.6)	8.3 (28.2)	10 (34.2)	13.4 (45.7)
Sensible, kW (MBH)	6.9 (23.6)	8.1 (27.5)	8.4 (28.8)	12.5 (42.7)
<b>72 °F DB/60.0 °F WB, 50% RH, 52.3 °F DP</b>				
Total, kW (MBH)	7.1 (24.2)	7.9 (27.1)	9.7 (33.1)	13.1 (44.8)
Sensible, kW (MBH)	6.9 (23.4)	7.0 (24.0)	6.9 (23.6)	11.5 (39.1)

Model:	CC()-041-G-EC	CC()-061-G-EC	CC()-081-G-EC	CC()-121-G-EC
<b>NET DX COOLING CAPACITY - (Includes Motor Heat @ Rated ft<sup>3</sup>/min &amp; esp)</b>				
<b>80 °F DB/62.9 °F WB, 38% RH, 52.3 °F DP</b>				
Total, kW (MBH)	6.6 (22.6)	7.4 (25.4)	8.9 (30.5)	12.0 (41.0)
Sensible, kW (MBH)	6.6 (22.6)	7.4 (25.4)	8.9 (30.5)	12.0 (41.0)
<b>75 °F DB/61.1 °F WB, 45% RH, 52.3 °F DP</b>				
Total, kW (MBH)	6.0 (20.6)	6.9 (23.4)	8.6 (29.5)	11.3 (38.6)
Sensible, kW (MBH)	6.0 (20.6)	6.9 (23.4)	8.2 (28.1)	11.3 (38.6)
<b>72 °F DB/60.0 °F WB, 50% RH, 52.3 °F DP</b>				
Total, kW (MBH)	5.9 (20.1)	7.0 (24.0)	8.4 (28.7)	11.2 (38.1)
Sensible, kW (MBH)	5.8 (19.9)	6.8 (23.1)	7.2 (24.6)	10.9 (37.3)

<b>Model:</b>		<b>CC()-110-C-EC</b>
<b>Chilled Water Control Valve - Sized for Medium Flow @ 75 °F DB/62.5 °F WB EAT Conditions</b>		
<b>3-way (standard) - Modulating</b>		
Size in. (Cv)	½ (5.0)	
Valve Pressure Rating, psi	600	
<b>2-way (optional) - Modulating</b>		
Size in. (Cv)	½ (5.0)	
Valve Pressure Rating, psi	600	
<b>Chilled Water Coil - Aluminum Fin, Copper Tube</b>		
Rows (Face Area, ft²)	4 (3.25)	
Face Velocity, ft/min	581	
<b>Chilled Water Coil Blower / Motor - Backward Curved EC</b>		
Nominal Motor Power, hp	1.3	
Rated Air Flow, ft³/min @ 0.2 inH <sub>2</sub> O esp	1,890	
Quantity of Blowers	1	
<b>Reheat/Heat - Performance Capacities Include Evaporator Blower Motor Heat</b>		
<b>Electric Reheat / Heat (Standard)</b>		
Number of Stages	1	
Total Nominal Capacity, kW (MBH)	6 (20.5)	
<b>Hot Water Reheat / Heat (Optional) - Reheat Rated @ 180 °F Entering Water Temperature, EAT = 72 °F DB</b>		
Total Capacity, kW (MBH)	18.6 (63.5)	
Flow Rate, gpm (Pressure Drop, ftH <sub>2</sub> O)	6.5 (.8)	
Control Valve	on/off	
<b>Humidification (Standard) - Electrode Steam Canister Humidifier with Adjustable Output</b>		
Steam Output, lb/hr (Power Input, kW)	2-5 (1.7)	
Std Control	Cycling	
<b>Filters (Standard) - Disposable, MERV 8 Average Dust Spot Efficiency</b>		
Up-flow, Front Free Return. Actual Size (in.) (Quantity)	20 × 23 (1)	
Up-flow, Rear-ducted Return. Actual Size (in.) (Quantity)	20 × 25 (1)	
Down-flow. Actual Size (in.) (Quantity)	20 × 23 (1)	
<b>Connection Sizes - Copper (Please refer to Mini-Space EC IOM Manual for interconnecting refrigerant line sizing.)</b>		
Condensate Drain, in. OD	7/8	
Humidifier Inlet, in. OD	1/4	
Water In and Out, in. OD	7/8	
<b>Physical Data</b>		
Approximate Unit Weight, lb	400	
Unit Dimensions, H in. x W in. x D in. CCU/D/F-()-A	73 × 25 × 24	
Unit Dimensions, H in. x W in. x D in. CCR-()-A	73 × 25 × 44	
Shipping Dimensions, H in. x W in. x D in. CCU/D/F-()-A	81 × 33 × 32	
Shipping Dimensions, H in. x W in. x D in. CCR-()-A	81 × 33 × 52	

Model:		CC()-110-C-EC
<b>NET COOLING CAPACITY @ 50 °F EWT, 0% Glycol Solution (Includes motor heat @ rated ft<sup>3</sup>/min &amp; esp)</b>		
<b>85° F DB/65.9 °F WB, 36% RH, 55 °F DP</b>		
<b>High Flow (10°F ΔTw)</b>	Total kW (MBH)	11.3 (38.7)
	Sensible kW (MBH)	11.3 (38.7)
	Flow Rate, gpm (Pressure Drop, ftH <sub>2</sub> O)	8.4 (20.8)
<b>Med. Flow (12°F ΔTw)</b>	Total kW (MBH)	10.6 (36.0)
	Sensible kW (MBH)	10.6 (36.0)
	Flow Rate, gpm (Pressure Drop, ftH <sub>2</sub> O)	6.6 (14.3)
<b>Low Flow (14°F ΔTw)</b>	Total kW (MBH)	9.8 (33.3)
	Sensible kW (MBH)	9.8 (33.3)
	Flow Rate, gpm (Pressure Drop, ftH <sub>2</sub> O)	5.3 (10.6)
<b>80° F DB/64.2 °F WB, 42% RH, 55 °F DP</b>		
<b>High Flow (10°F ΔTw)</b>	Total kW (MBH)	9.1 (30.9)
	Sensible kW (MBH)	9.1 (30.9)
	Flow Rate, gpm (Pressure Drop, ftH <sub>2</sub> O)	6.8 (15.0)
<b>Med. Flow (12°F ΔTw)</b>	Total kW (MBH)	8.3 (28.3)
	Sensible kW (MBH)	8.3 (28.3)
	Flow Rate, gpm (Pressure Drop, ftH <sub>2</sub> O)	5.3 (10.6)
<b>Low Flow (14°F ΔTw)</b>	Total kW (MBH)	7.4 (25.3)
	Sensible kW (MBH)	7.4 (25.3)
	Flow Rate, gpm (Pressure Drop, ftH <sub>2</sub> O)	4.1 (7.7)
<b>75 °F DB/62.5 °F WB, 50% RH, 55 °F DP</b>		
<b>High Flow (10°F ΔTw)</b>	Total kW (MBH)	6.8 (23.1)
	Sensible kW (MBH)	6.8 (23.1)
	Flow Rate, gpm (Pressure Drop, ftH <sub>2</sub> O)	5.3 (10.6)
<b>Med. Flow (12°F ΔTw)</b>	Total kW (MBH)	5.9 (20.1)
	Sensible kW (MBH)	5.9 (20.1)
	Flow Rate, gpm (Pressure Drop, ftH <sub>2</sub> O)	3.9 (7.3)
<b>Low Flow (14°F ΔTw)</b>	Total kW (MBH)	5.0 (17.0)
	Sensible kW (MBH)	5.0 (17.0)
	Flow Rate, gpm (Pressure Drop, ftH <sub>2</sub> O)	2.9 (5.5)
<b>85 °F DB/64.5 °F WB, 32% RH, 52 °F DP</b>		
<b>High Flow (10°F ΔTw)</b>	Total kW (MBH)	11.3 (38.6)
	Sensible kW (MBH)	11.3 (38.6)
	Flow Rate, gpm (Pressure Drop, ftH <sub>2</sub> O)	8.4 (20.8)
<b>Med. Flow (12°F ΔTw)</b>	Total kW (MBH)	10.5 (36.0)
	Sensible kW (MBH)	10.5 (36.0)
	Flow Rate, gpm (Pressure Drop, ftH <sub>2</sub> O)	6.6 (14.3)
<b>Low Flow (14°F ΔTw)</b>	Total kW (MBH)	9.7 (33.2)
	Sensible kW (MBH)	9.7 (33.2)
	Flow Rate, gpm (Pressure Drop, ftH <sub>2</sub> O)	5.2 (10.4)
<b>80° F DB/62.9 °F WB, 38% RH, 52 °F DP</b>		
<b>High Flow (10°F ΔTw)</b>	Total kW (MBH)	9.1 (30.9)
	Sensible kW (MBH)	9.1 (30.9)
	Flow Rate, gpm (Pressure Drop, ftH <sub>2</sub> O)	6.8 (15.0)
<b>Med. Flow (12°F ΔTw)</b>	Total kW (MBH)	8.2 (28.1)
	Sensible kW (MBH)	8.2 (28.1)
	Flow Rate, gpm (Pressure Drop, ftH <sub>2</sub> O)	5.2 (10.4)
<b>Low Flow (14°F ΔTw)</b>	Total kW (MBH)	7.4 (25.2)
	Sensible kW (MBH)	7.4 (25.2)
	Flow Rate, gpm (Pressure Drop, ftH <sub>2</sub> O)	4.1 (7.7)
<b>75 °F DB/61.1 °F WB, 45% RH, 52 °F DP</b>		
<b>High Flow (10°F ΔTw)</b>	Total kW (MBH)	6.8 (23.0)
	Sensible kW (MBH)	6.8 (23.0)
	Flow Rate, gpm (Pressure Drop, ftH <sub>2</sub> O)	5.2 (10.4)
<b>Med. Flow (12°F ΔTw)</b>	Total kW (MBH)	5.9 (20.1)
	Sensible kW (MBH)	5.9 (20.1)
	Flow Rate, gpm (Pressure Drop, ftH <sub>2</sub> O)	3.9 (7.3)
<b>Low Flow (14°F ΔTw)</b>	Total kW (MBH)	5.0 (17.0)
	Sensible kW (MBH)	5.0 (17.0)
	Flow Rate, gpm (Pressure Drop, ftH <sub>2</sub> O)	2.9 (5.5)

Model:		CCJ-110-C-EC
<b>NET COOLING CAPACITY @ 45 °F EWT, 0% Glycol Solution (Includes motor heat @ rated ft<sup>3</sup>/min &amp; esp)</b>		
<b>85 °F DB/65.9 °F WB, 36% RH, 55 °F DP</b>		
<b>High Flow (10°F ΔTw)</b>	Total kW (MBH)	13.5 (46.1)
	Sensible kW (MBH)	13.5 (46.1)
	Flow Rate, gpm (Pressure Drop, ftH <sub>2</sub> O)	9.9 (27.3)
<b>Med. Flow (12°F ΔTw)</b>	Total kW (MBH)	12.7 (43.5)
	Sensible kW (MBH)	12.7 (43.5)
	Flow Rate, gpm (Pressure Drop, ftH <sub>2</sub> O)	7.8 (18.6)
<b>Low Flow (14°F ΔTw)</b>	Total kW (MBH)	11.9 (40.8)
	Sensible kW (MBH)	11.9 (40.8)
	Flow Rate, gpm (Pressure Drop, ftH <sub>2</sub> O)	6.3 (13.5)
<b>80 °F DB/64.2 °F WB, 42% RH, 55 °F DP</b>		
<b>High Flow (10°F ΔTw)</b>	Total kW (MBH)	12.2 (41.7)
	Sensible kW (MBH)	11.9 (40.5)
	Flow Rate, gpm (Pressure Drop, ftH <sub>2</sub> O)	9.0 (23.4)
<b>Med. Flow (12°F ΔTw)</b>	Total kW (MBH)	10.5 (35.8)
	Sensible kW (MBH)	10.5 (35.8)
	Flow Rate, gpm (Pressure Drop, ftH <sub>2</sub> O)	6.5 (14.1)
<b>Low Flow (14°F ΔTw)</b>	Total kW (MBH)	9.7 (32.9)
	Sensible kW (MBH)	9.7 (32.9)
	Flow Rate, gpm (Pressure Drop, ftH <sub>2</sub> O)	5.2 (10.4)
<b>75 °F DB/62.5 °F WB, 50% RH, 55 °F DP</b>		
<b>High Flow (10°F ΔTw)</b>	Total kW (MBH)	10.0 (34.2)
	Sensible kW (MBH)	9.5 (32.4)
	Flow Rate, gpm (Pressure Drop, ftH <sub>2</sub> O)	7.5 (17.5)
<b>Med. Flow (12°F ΔTw)</b>	Total kW (MBH)	8.2 (27.9)
	Sensible kW (MBH)	8.2 (27.9)
	Flow Rate, gpm (Pressure Drop, ftH <sub>2</sub> O)	5.2 (10.4)
<b>Low Flow (14°F ΔTw)</b>	Total kW (MBH)	7.3 (25.0)
	Sensible kW (MBH)	7.3 (25.0)
	Flow Rate, gpm (Pressure Drop, ftH <sub>2</sub> O)	4.0 (7.5)
<b>85 °F DB/64.5 °F WB, 32% RH, 52 °F DP</b>		
<b>High Flow (10°F ΔTw)</b>	Total kW (MBH)	13.5 (46.0)
	Sensible kW (MBH)	13.5 (46.0)
	Flow Rate, gpm (Pressure Drop, ftH <sub>2</sub> O)	9.9 (27.3)
<b>Med. Flow (12°F ΔTw)</b>	Total kW (MBH)	12.7 (43.4)
	Sensible kW (MBH)	12.7 (43.4)
	Flow Rate, gpm (Pressure Drop, ftH <sub>2</sub> O)	7.8 (18.6)
<b>Low Flow (14°F ΔTw)</b>	Total kW (MBH)	11.9 (40.7)
	Sensible kW (MBH)	11.9 (40.7)
	Flow Rate, gpm (Pressure Drop, ftH <sub>2</sub> O)	6.3 (13.5)
<b>80 °F DB/62.9 °F WB, 38% RH, 52 °F DP</b>		
<b>High Flow (10°F ΔTw)</b>	Total kW (MBH)	11.3 (38.6)
	Sensible kW (MBH)	11.3 (38.6)
	Flow Rate, gpm (Pressure Drop, ftH <sub>2</sub> O)	8.4 (20.9)
<b>Med. Flow (12°F ΔTw)</b>	Total kW (MBH)	10.5 (35.8)
	Sensible kW (MBH)	10.5 (35.8)
	Flow Rate, gpm (Pressure Drop, ftH <sub>2</sub> O)	6.5 (14.1)
<b>Low Flow (14°F ΔTw)</b>	Total kW (MBH)	9.6 (32.9)
	Sensible kW (MBH)	9.6 (32.9)
	Flow Rate, gpm (Pressure Drop, ftH <sub>2</sub> O)	5.2 (10.4)
<b>75 °F DB/61.1 °F WB, 45% RH, 52 °F DP</b>		
<b>High Flow (10°F ΔTw)</b>	Total kW (MBH)	9.0 (30.8)
	Sensible kW (MBH)	9.0 (30.8)
	Flow Rate, gpm (Pressure Drop, ftH <sub>2</sub> O)	6.8 (15.1)
<b>Med. Flow (12°F ΔTw)</b>	Total kW (MBH)	8.2 (28.0)
	Sensible kW (MBH)	8.2 (28.0)
	Flow Rate, gpm (Pressure Drop, ftH <sub>2</sub> O)	5.2 (10.5)
<b>Low Flow (14°F ΔTw)</b>	Total kW (MBH)	7.3 (24.9)
	Sensible kW (MBH)	7.3 (24.9)
	Flow Rate, gpm (Pressure Drop, ftH <sub>2</sub> O)	4.0 (7.5)

Performance Data - Chilled Water - 45 °F EWT

## With Condensate Pump

Model	CCU/D-041-A/W/G-EC					CCU/D-061-A/W/G-EC					CCU/D-081-A/W/G-EC				
	FLA			MCA	MFS	FLA			MCA	MFS	FLA			MCA	MFS
	A	W	G			A	W	G			A	W	G		
<b>Cooling w/ Electric Reheat/Heat &amp; Humidification</b>															
208/1/60	26.4	24.4	27.0	37.7	45	27.8	25.4	28.5	36.8	45	30.5	27.6	31.4	41.7	50
208/3/60	23.0	21.9	23.3	28.9	30	24.0	22.7	24.4	30.4	35	25.8	24.5	26.2	33.0	40
460/3/60	11.1	10.5	11.3	14.0	15	11.6	11.0	11.8	16.0	20	12.5	11.9	12.8	16.9	20
<b>Cooling w/ Electric Reheat/Heat Only (No Humidifier)</b>															
208/1/60	26.4	24.4	27.0	37.7	45	27.8	25.4	28.5	36.8	45	30.5	27.6	31.4	41.7	50
208/3/60	23.0	21.9	23.3	28.9	30	24.0	22.7	24.4	30.4	35	25.8	24.5	26.2	33.0	40
460/3/60	11.1	10.5	11.3	14.0	15	11.6	11.0	11.8	16.0	20	12.5	11.9	12.8	16.9	20
<b>Cooling w/ Humidification Only (No Heat/Reheat)</b>															
208/1/60	22.8	20.8	23.4	31.2	40	24.2	21.8	24.9	30.3	40	26.9	24.0	27.8	35.2	50
208/3/60	19.4	18.3	19.7	22.4	25	20.4	19.1	20.8	23.9	30	22.2	20.9	22.6	26.5	35
460/3/60	9.4	8.8	9.6	10.8	15	9.9	9.3	10.1	12.8	15	10.8	10.2	11.1	13.7	15
<b>Cooling Only</b>															
208/1/60	14.6	12.6	15.2	23.0	35	16.0	13.6	16.7	22.1	30	18.7	15.8	19.6	27.0	40
208/3/60	11.2	10.1	11.5	14.2	20	12.2	10.9	12.6	15.7	20	14.0	12.7	14.4	18.3	25
460/3/60	5.5	4.9	5.7	7.0	15	6.0	5.4	6.2	9.0	15	6.9	6.3	7.2	9.9	15

Model	CCU/D-121-A/W/G				
	FLA			MCA	MFS
	A	W	G		
<b>Cooling w/ Electric Reheat/Heat &amp; Humidification</b>					
208/1/60	46.9	42.8	48.1	62.8	70
208/3/60	29.6	27.4	30.2	39.4	45
460/3/60	15.3	14.5	15.6	19.7	20
<b>Cooling w/ Electric Reheat /Heat Only (No Humidifier)</b>					
208/1/60	46.9	42.8	48.1	62.8	70
208/3/60	29.6	27.4	30.2	39.4	45
460/3/60	15.3	14.5	15.6	19.7	20
<b>Cooling w/ Humidification (No Heat/Reheat)</b>					
208/1/60	31.5	27.4	32.7	41.5	60
208/3/60	24.2	22.0	24.8	30.6	40
460/3/60	11.7	10.9	12.0	14.2	20
<b>Cooling Only</b>					
208/1/60	23.3	19.2	24.5	33.3	50
208/3/60	16.0	13.8	16.6	22.4	35
460/3/60	7.8	7.0	8.1	10.4	15

### Without Condensate Pump

Model	CCU/D-041-A/W/G-EC					CCU/D-061-A/W/G-EC					CCU/D-081-A/W/G-EC				
	FLA			MCA	MFS	FLA			MCA	MFS	FLA			MCA	MFS
	A	W	G			A	W	G			A	W	G		
<b>Cooling w/ Electric Reheat/Heat &amp; Humidification</b>															
208/1/60	24.5	22.5	25.1	35.8	45	25.9	23.5	26.6	34.9	40	28.6	25.7	29.5	39.8	50
208/3/60	21.1	20.0	21.4	27.0	30	22.1	20.8	22.5	28.5	30	23.9	22.6	24.3	31.1	35
460/3/60	10.3	9.7	10.5	13.2	15	10.8	10.2	11.0	15.2	20	11.7	11.1	12.0	16.1	20
<b>Cooling w/ Electric Reheat/Heat Only (No Humidifier)</b>															
208/1/60	24.5	22.5	25.1	35.8	45	25.9	23.5	26.6	34.9	40	28.6	25.7	29.5	39.8	50
208/3/60	21.1	20.0	21.4	27.0	30	22.1	20.8	22.5	28.5	30	23.9	22.6	24.3	31.1	35
460/3/60	10.3	9.7	10.5	13.2	15	10.8	10.2	11.0	15.2	20	11.7	11.1	12.0	16.1	20
<b>Cooling w/ Humidification Only (No Heat/Reheat)</b>															
208/1/60	20.9	18.9	21.5	29.3	40	22.3	19.9	23.0	28.4	40	25.0	22.1	25.9	33.3	45
208/3/60	17.5	16.4	17.8	20.5	25	18.5	17.2	18.9	22.0	30	20.3	19.0	20.7	24.6	35
460/3/60	8.6	8.0	8.8	10.0	15	9.1	8.5	9.3	12.0	15	10.0	9.4	10.3	12.9	15
<b>Cooling Only</b>															
208/1/60	12.7	10.7	13.3	21.1	30	14.1	11.7	14.8	20.2	30	16.8	13.9	17.7	25.1	40
208/3/60	9.3	8.2	9.6	12.3	15	10.3	9.0	10.7	13.8	20	12.1	10.8	12.5	16.4	25
460/3/60	4.7	4.1	4.9	6.2	15	5.2	4.6	5.4	8.2	15	6.1	5.5	6.4	9.1	15

Model	CCU/D-121-A/W/G-EC				
	FLA			MCA	MFS
	A	W	G		
<b>Cooling w/ Electric Reheat/Heat &amp; Humidification</b>					
208/1/60	45.0	40.9	46.2	60.9	70
208/3/60	27.7	25.5	28.3	37.5	45
460/3/60	14.5	13.7	14.8	18.9	20
<b>Cooling w/ Electric Reheat /Heat Only (No Humidifier)</b>					
208/1/60	45.0	40.9	46.2	60.9	70
208/3/60	27.7	25.5	28.3	37.5	45
460/3/60	14.5	13.7	14.8	18.9	20
<b>Cooling w/ Humidification (No Heat/Reheat)</b>					
208/1/60	29.6	25.5	30.8	39.6	60
208/3/60	22.3	20.1	22.9	28.7	40
460/3/60	10.9	10.1	11.2	13.4	15
<b>Cooling Only</b>					
208/1/60	21.4	17.3	22.6	31.4	50
208/3/60	14.1	11.9	14.7	20.5	30
460/3/60	7.0	6.2	7.3	9.6	15

### With Condensate Pump

Model	CCU/D-110-C-EC		
	FLA	MCA	MFS
<b>Cooling w/ Electric Reheat/Heat &amp; Humidification</b>			
208/1/60	37.9	47.4	50
208/3/60	27.1	33.9	35
460/3/60	14.0	17.5	20
<b>Cooling w/ Electric Reheat/Heat Only (No Humidifier)</b>			
208/1/60	29.7	37.1	40
208/3/60	18.9	23.6	25
460/3/60	10.1	12.6	15
<b>Cooling w/ Humidification Only (No Heat/Reheat)</b>			
208/1/60	14.3	17.9	20
208/3/60	13.5	16.9	20
460/3/60	6.5	8.1	15
<b>Cooling Only</b>			
208/1/60	6.1	7.6	15
208/3/60	5.3	6.8	15
460/3/60	2.6	3.3	15

### Without Condensate Pump

Model	CCU/D-110-C-EC		
	FLA	MCA	MFS
<b>Cooling w/ Electric Reheat/Heat &amp; Humidification</b>			
208/1/60	36.0	45.0	45
208/3/60	25.2	31.5	35
460/3/60	13.2	16.5	20
<b>Cooling w/ Electric Reheat/Heat Only (No Humidifier)</b>			
208/1/60	27.8	34.7	35
208/3/60	17.0	21.2	25
460/3/60	9.3	11.6	15
<b>Cooling w/ Humidification Only (No Heat/Reheat)</b>			
208/1/60	12.4	15.5	20
208/3/60	11.6	14.5	15
460/3/60	5.7	7.1	15
<b>Cooling Only</b>			
208/1/60	4.2	5.2	15
208/3/60	3.4	4.2	15
460/3/60	1.8	2.3	15



**CCU/CCR-041/061/081/121-A, W, G-EC, & -110-C-EC**

"Up-Flow" Front and Rear Return Vertical A/C  
("Ducted" or optional "2- or 3-way plenum box")

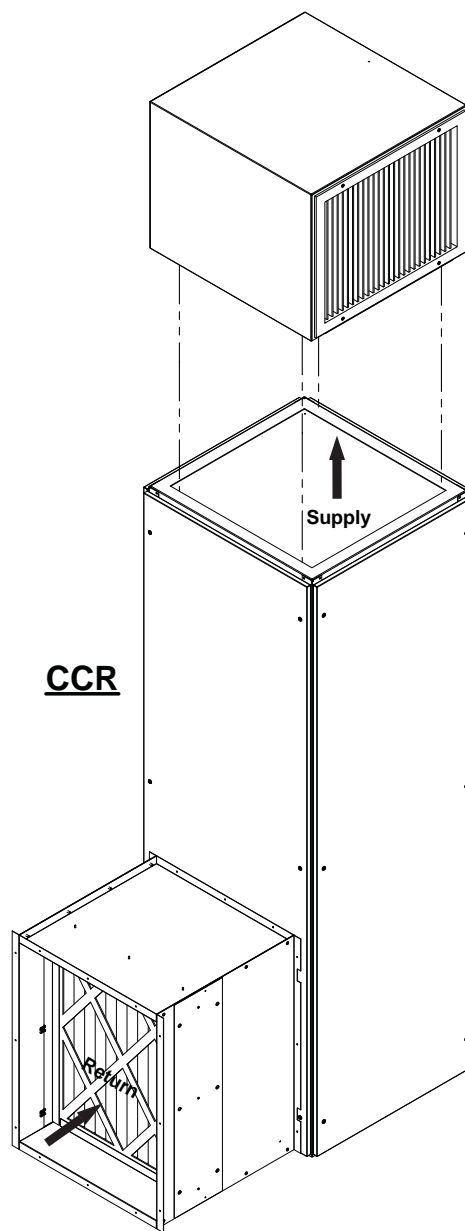
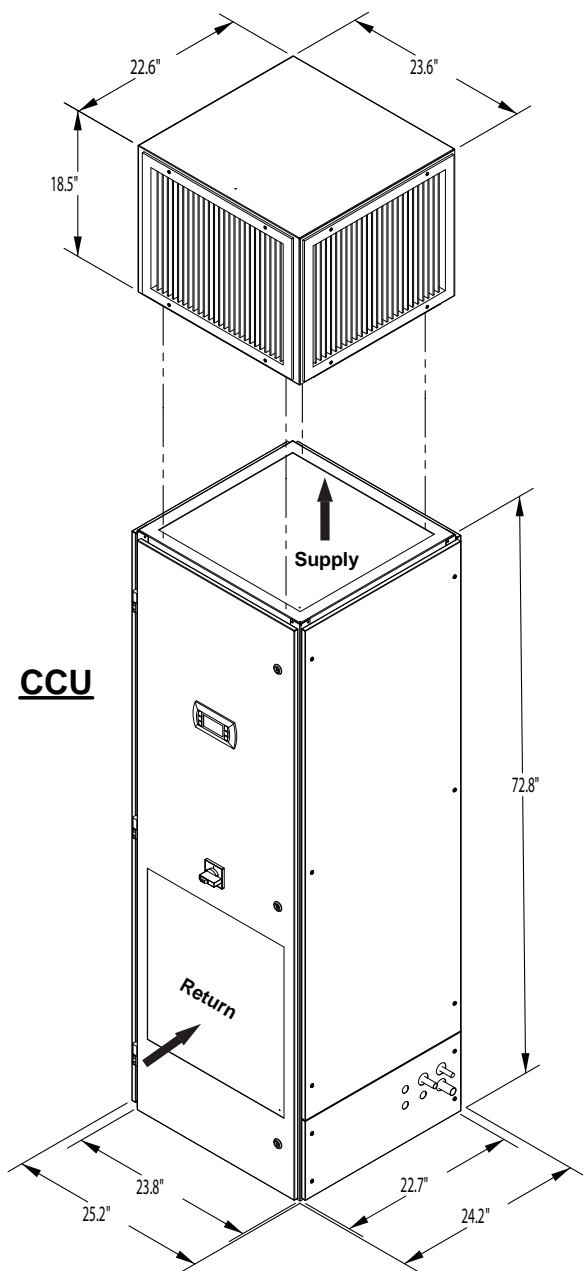

Adjustable Floor Stand (Optional)

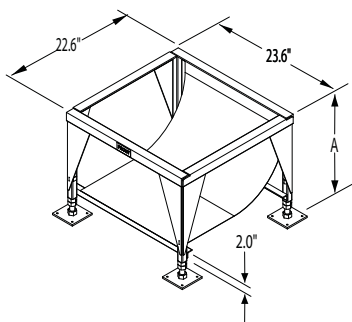

DIMENSIONAL DATA - FLOOR STAND HEIGHTS			
NOMINAL HEIGHT	"A" DIMENSION		TURNING VANE
	ADJUSTABLE HEIGHT MAX	ADJUSTABLE HEIGHT MIN	
4" upflow only	3.5"	4.5"	Not available
6"	5.0"	7.0"	Not available
12"	11.0"	15.0"	Optional
15"	14.0"	18.0"	Optional
18"	17.0"	21.0"	Optional
24"	23.0"	26.0"	Optional

**CCD/CCF-041/061/081/121-A, W, G-EC &  
-110-C-EC**

*"Down-Flow" & Front Discharge Vertical A/C  
("Free Return" or with optional "Ducted Return")*

Dimensional Data

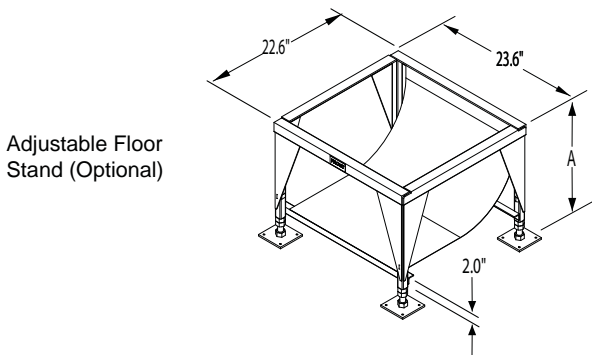
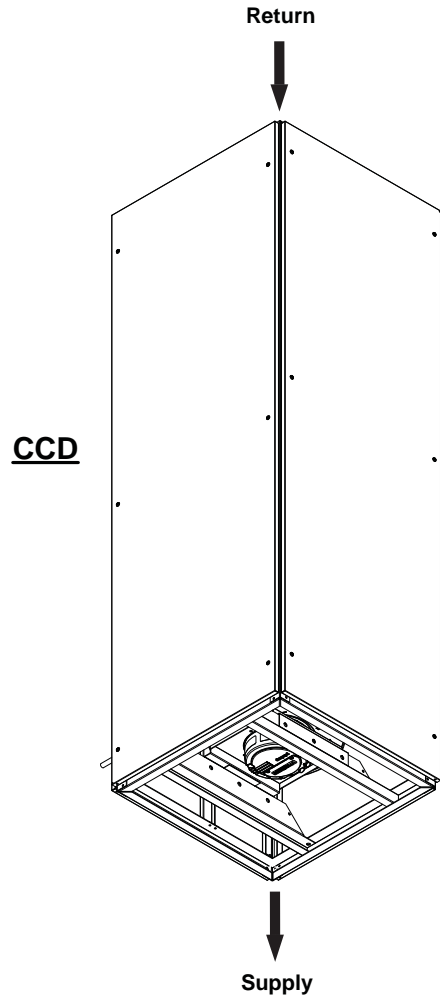
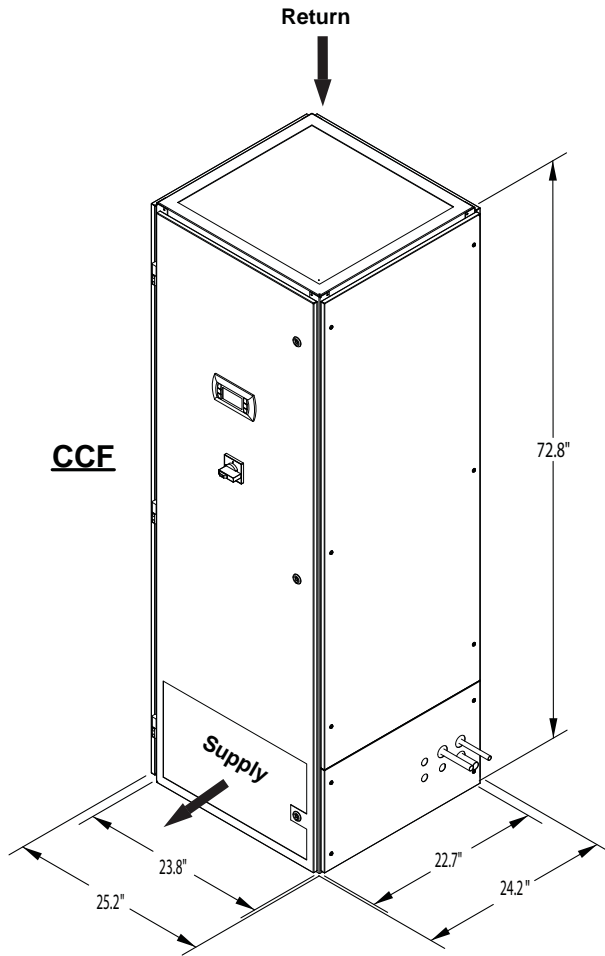

DIMENSIONAL DATA - FLOOR STAND HEIGHTS			
NOMINAL HEIGHT	"A" DIMENSION		TURNING VANE
	ADJUSTABLE HEIGHT		
	MAX	MIN	
4" upflow only	3.5"	4.5"	Not available
6"	5.0"	7.0"	Not available
12"	11.0"	15.0"	Optional
15"	14.0"	18.0"	Optional
18"	17.0"	21.0"	Optional
24"	23.0"	26.0"	Optional

**STULZ Mini-Space EC**  
**4 –12 kW DX and CW**  
**Floor Mounted**  
**Precision Air Conditioners**

**SUMMARY**

This specification describes requirements for a precision environmental control system. The STULZ Mini-Space EC floor-mounted air conditioning system shall provide precision temperature and/or humidity control for computer rooms or rooms containing telecommunications or other highly-sensitive heat load equipment where continuous 24 hour a day, 365 days a year air conditioning is required. Designed for front access, Mini-Space EC systems require minimum floor space. The units are designed with a wide range of options to handle both precision and comfort cooling applications.

The Mini-Space EC model number shall be CC \_ - \_ - \_ - \_ - EC.

**DESIGN REQUIREMENTS**

The environmental control system shall be a Mini-Space EC factory-assembled unit. The unit shall be designed for corner installation, requiring front access through hinged front access panels. No allowance for side service access shall be required.

Mini-Space EC units are especially adapted for both raised and non-raised floors. The system shall be specifically designed for high sensible heat ratio. Each system shall be capable of handling \_\_\_ ft<sup>3</sup>/min. The unit shall have a total cooling capacity of \_\_\_ BTU/H, and a sensible cooling capacity of \_\_\_ BTU/H based on entering air conditions of \_\_\_ °F dry bulb and \_\_\_ °F wet bulb. The main fan motors shall be \_\_\_ HP. The unit shall have a power supply of \_\_\_ volts.

**QUALITY ASSURANCE**

The manufacturer shall maintain a set of international standards of quality management to insure product quality. Each system shall be subjected to a complete operational and functional test procedure at the factory prior to shipment.

**CABINET**

Access panels shall be fabricated from heavy gauge steel and shall be securely attached to the frame. Access panels shall be powder coated to match and provide corrosion protection. The panels shall be lined with 1/2" (13 mm), 2 lb/ft<sup>2</sup> (.90 kg), high-density sound and thermal insulation and sealed with self-extinguishing gasketing conforming to NFPA 90A and 90B.

**AIR FLOW PATTERNS**

**Up-Flow:**

**CCU-(-)(-)-EC**

The air conditioner shall be configured for an up-flow air pattern with free evaporator return air through front filtered grille and conditioned supply air through the top of the unit.

**CCR-(-)(-)-EC**

The air conditioner shall be configured for an up-flow air pattern with free evaporator return air through a rear filtered box and conditioned supply air through the top of the unit.

**Down-Flow:**

**CCD-(-)(-)-EC**

The air conditioner shall be configured for a down-flow air pattern with free evaporator return air to the top and conditioned supply air discharge through the bottom of the A/C into the raised floor.

**CCF-(-)(-)-EC**

The air conditioner shall be configured for a down-flow air pattern with free evaporator return air to the top and conditioned supply air discharge through the front of the A/C.

**AIR FILTRATION**

All units shall be supplied with disposable air filters classified as UL 900 or UL 586. Filters shall be 2" deep (nominal). Filters shall be pleated with a Minimum Efficiency Reporting Value (MERV) of 8.

Optional: Filters rated up to MERV 11, shall be available.

**MECHANICAL COMPONENTS**

**BLOWER**

**Backward Inclined, Plenum Style Fan, with an EC Motor**

The blower shall be a direct driven, single inlet, two-fold backward curved radial fan with an electronically commutated motor for maintenance free operation. The motor shall include: integrated electronic control board and direct microprocessor control signaling for fan speed control, soft-starting capabilities, RS-485 BUS connection, and integrated current limitations. Each fan shall be low noise, low vibration manufactured with an anti-corrosive aluminum impeller. The fan impeller shall be dynamically and statically balanced in two planes to minimize vibration during operation.

**DX REFRIGERATION SYSTEM**

All refrigeration piping shall be refrigerant grade tubing. Each refrigerant circuit shall include, as a minimum, refrigerant drier/strainer, sight glass with moisture detector, thermal expansion valve with rapid bleed port feature and external equalizer, evaporator coil, compressor, high pressure switch with manual reset and a low pressure switch with automatic reset.

Split/Remote systems shall have a liquid line solenoid for refrigerant isolation to prevent liquid slugging. All high pressure joints shall be brazed and the entire system shall be pressure tested at the factory with dry nitrogen, evacuated to at least 50 microns and fully charged with refrigerant.

### Scroll Compressor

The compressor shall be a high efficiency, high reliability and low sound scroll compressor.

The compressor shall be complete with charging and service Schrader ports, internal vibration isolation, internal thermal overloads, internal pressure relief valve, internal discharge gas vibration eliminator and external vibration mounting isolation.

### Evaporator Coil

Evaporator systems shall be configured for a draw-thru air pattern to provide uniform air distribution over the evaporator coil face. The coil shall be seamless drawn copper tubes, mechanically bonded to tempered aluminum fins with fin pattern designed for maximum heat transfer. Coil end plates shall be hot dipped galvanized.

The evaporator coil shall be mounted in an insulated stainless steel condensate drain pan.

### Snap-Acting Hot Gas Bypass (Optional)

The Mini-Space EC air conditioning system shall incorporate a snap acting hot gas bypass system to provide modulation of the unit's cooling capacity and evaporator coil freeze protection under low load conditions.

### Air-Cooled Heat Rejection

#### -20 °F, Variable Fan Speed Control

The air cooled system shall incorporate a low ambient variable speed fan head pressure control for year-round air conditioning system operation down to -20 °F DB minimum ambient air temperature.

#### -30 °F, Flooded Control

The air cooled system shall incorporate a low ambient flooded head pressure control for year-round system operation down to -30 °F DB minimum ambient air temperature.

This option shall include factory installed crankcase heaters, cold-start relays, liquid refrigerant receivers with receiver liquid level sight glass and head pressure regulating valves for flooded condenser operation.

### Water/Glycol Cooled Heat Rejection

The evaporator refrigerant circuit shall be provided with a factory installed single pass, counterflow configured brazed plate heat exchanger, with integral subcooler, constructed of type 316 stainless steel; designed and tested for a 650 psig wwp.

### 2-Way, 600 psig Regulating Valve

The refrigerant circuit's head pressure shall be controlled by a factory installed 2-way water / glycol regulating valve rated for 600 psig wwp.

### 3-Way, 600 psig Regulating Valve (Optional)

The refrigerant circuit's head pressure shall be controlled by a factory installed 3-way water / glycol regulating valve rated for 600 psig wwp.

## CHILLED WATER

### Cooling Coil

The chilled water cooling coil shall be constructed of seamless drawn copper tubes, mechanically bonded to tempered aluminum fins for maximum heat transfer. Coil end plated shall be hot dipped galvanized.

The cooling coil shall be mounted in an insulated aluminum condensate drain pan.

### CW Control Valves

Chilled water cooling shall be controlled by the following standard and optional control valves:

V1: 3-way, 600 psig (standard)

V2: 2-way, 600 psig (optional)

A \_\_\_\_-way modulating CW cooling control valve rated for a maximum \_\_\_\_\_ psig wwp. shall be factory installed. Precision cooling control shall be accomplished via a modulating control signal to the control valve.

## STEAM GENERATING HUMIDIFIER (STANDARD)

The humidifier shall be a self-contained atmospheric steam generator. The humidifier assembly shall include an integral fill cup, fill and drain valves, disposable steam cylinder and associated piping. The humidifier shall be equipped with an auto adaptive control system to optimize water conductivity, control automatic drain/flush cycles, minimize energy waste and maximize cylinder life. Drain water tempered fill water shall insure drains do not exceed 140 °F during operation. The humidifier shall have modulating output between 20% and 100% of rated capacity.

#### Note:

The humidifier is not available in units equipped with the Low Entering Condenser Water kit option described on page 19.

### Dehumidification Cycle (Standard)

The system shall be provided with a dehumidification control mode. Moisture is condensed on the cooling coil and discharged through the condensate drain. Reheat shall be provided to offset sensible cooling during the dehumidification cycle.

## REHEAT

### Electric Heat/ Reheat (Standard)

A factory mounted and wired low-watt density, plated fin-tubular design electric resistance heater shall be included to provide automatic sensible re-heating as required during the dehumidification cycle and automatic heating mode. Electric heaters shall be provided with miniature thermal/magnetic circuit breakers, which shall protect each ungrounded conductor. Also included will be

one automatic reset and one manual reset over-temperature safety device (pilot duty).

### Hot Water/Steam Reheat/Heat (Optional)

A factory-installed, copper tube, aluminum fin heat/reheat coil and 2-way control valve shall be provided to control the flow of hot water for automatic sensible reheating mode during the dehumidification cycle and automatic heating mode as required.

### Hot Gas Reheat (Optional)

#### (Models CC(-)(-)-A, W, & G-EC only)

A factory-installed copper tube, aluminum-fin hot gas reheat coil and valve shall be provided for automatic sensible reheating mode during dehumidification cycle. Hot compressor discharge gas shall be diverted from the condenser to the hot gas reheat coil providing energy-free sensible reheating.

## ELECTRICAL SYSTEM

The electrical system shall conform to National Electrical Code requirements. The control circuit shall be 24 volts AC, wired in accordance with NEC Class II requirements. The control circuit wire shall not be smaller than 18 AWG. All wiring shall be neatly wrapped and routed in bundles. Each wire shall end with a service loop and be securely fastened by an approved method. Each wire in the unit shall be numbered for ease of service tracing.

All electrically actuated components shall be easily accessible from the front of the unit without reaching over exposed high voltage components or rotating parts. Each high voltage circuit shall be individually protected by circuit breakers or manual motor starters on all three phases. The blower motor shall have thermal and short circuit protection. Line voltage and 24 volt control circuit wiring shall be routed in separate bundles.

The electric box shall be positioned for service convenience and shall include all the contactors, starters, fuses, circuit breakers, terminal boards and control transformer required for operation of the STULZ unit and shall allow for full service access.

### Main Power Service Switch

The Mini-Space EC shall be provided with a unit-mounted main power service switch.

### Remote Stop/Start Contacts

Included in the system's electrical control circuit shall be a 2-pin terminal connection for remote stop/start of the Mini-Space EC air conditioner by remote source.

## AIR CONTROL

### EC Fan Speed Control

The system shall include a variable fan speed control package. The unit's controller shall permit control of the fan speed from 100% rated air volumetric flow rate to a user define minimum fan speed setting. Minimum and maximum fan speed settings shall be user adjustable. User configured control sequences shall be available for fan speed energy savings control.

## E<sup>2</sup> SERIES CONTROLLER DESCRIPTION

### General

The advanced microprocessor based E<sup>2</sup>Series controller shall be equipped with flexible software capable of meeting the specific needs of the application. The setpoints shall be default and their ranges shall be easily viewed and adjusted from the user interface display. The program and operating parameters shall be permanently stored on a non-volatile system in the event of power failure.

The controller shall be designed to manage temperature and relative humidity (RH) levels to a user defined setpoint via control output signals to the system. Control parameters have variable outputs from 0 to 100% of the full rated capacity.

The controller shall receive inputs for measurable control conditions (temperature, relative humidity, and dew point) via return air or room mounted sensors. The internal logic will then determine if the conditions require cooling, humidification or dehumidification. Control setpoints shall be established to maintain design conditions of the installation. The controller will respond accordingly to changes in these conditions and control the output/demand for the appropriate mode of operation until user defined conditions are achieved.

### Field Configurable

The program for the E<sup>2</sup>Series controller shall be field configurable, allowing the operator to select control setpoints specific to the application. Operator interface for the E<sup>2</sup>controller is provided via a door mounted user interface graphic terminal. The graphic terminal shall have a backlit LCD graphical display and function keys giving the user complete control and monitoring capability of the precision cooling system. The menu-driven interface shall provide users the ability to scroll through and enter various menu screens.

### Password Protection

Access to the Info Menu, Alarms Log, and the ability to monitor room conditions shall be allowed without the use of a password. Modifications to the control setpoints shall require the use of a password. The controller shall be programmed to recognize predetermined security levels before allowing access to input screens containing critical variables. Three secured menu levels (Control, Service and Factory) will support unique passwords that must be entered to access the menu screens so only authorized personnel may perform modifications to the settings.

### Restorable Parameters/Factory Defaults

Upon initial start-up the system shall operate using the setpoints programmed by the factory. The customer may enter new operating parameters in the Control menu and the system will then operate accordingly. The new setpoints may be stored as "Customer Default Setpoints." The primary setpoints entered by the factory still remain stored in the controller's memory as "Factory Setpoints." The setpoints for the system may be re-adjusted in the Control menu at any time. If it becomes necessary, the customer may restore the setpoints back to the Customer Default setpoint values or to the original Factory setpoint values.

## Timer Feature

A timer shall allow the user to set up an operating schedule to automatically scale back or shut down the air conditioner during low demand or unoccupied periods. This is an energy saving feature offering the user the ability to create an operating schedule tailored to the needs of the building. An evening (night-setback) schedule may also be created, allowing the system to operate at night with relaxed temperature/humidity setpoints and offsets.

## A/C Grouping pLAN Operation

Multiple Mini-Space EC  $E^2$  controllers shall be able to be connected (grouped) to a pLAN local network, allowing the communication of data and information from each controller to a central control terminal or Lead controller. The Lead controller display screens can be used to monitor and adjust group control variables for the individual system controllers. Each  $E^2$  controller connected to the pLAN network shall be identified with its own unique address.

Multiple Mini-Space EC systems consisting of up to eight STULZ precision air conditioners equipped with like controllers may be controlled and monitored via the  $E^2$  controller. With multiple STULZ Mini-Space EC systems each unit can selectively be configured as "Active" to operate as a primary A/C, "Capacity Assist" for staged operation, or as "Standby" to come online in case of a failed air conditioning unit to ensure continuous availability. The controller may also be configured to rotate units with timed duty cycling to promote equal run-time and assure that each Mini-Space EC system within the rotating group is operationally exercised on a periodic timed basis.

## BMS Interface (Optional)

The  $E^2$  series controller shall incorporate a 10 Mbps communication interface port that can be field connected through a serial interface to a Building Management System via Modbus, BACnet, SNMP, or HTTP as configured by the factory. A controller interfaced to a network must be configured for BMS communication.

## Alarms

Alarm conditions shall activate a red LED indicator that backlights the alarm function key. As an option, an alarm condition may also be enunciated by an audible alarm signal. An alarm is acknowledged by pressing the alarm key. This calls up alarm display screens that provide a text message detailing the alarm conditions. After an alarm condition is corrected, the alarm can be cleared by pressing the alarm key.

## Controller Graphic Terminal

The graphic terminal features a character-based liquid-crystal display with adjustable contrast and LED illuminated function keys. The screens that appear on the graphic terminal display present data that originates from the controller.

The controller shall be operated via the graphic terminal keypad. The controller software provides an alarm log and four menu levels to the operator: Information, Control, Service, and Factory. These menus shall permit the user to easily view, control, and configure operating parameters for the Mini-Space EC system.

## OPTIONAL FEATURES

Mini-Space EC floor-mounted air conditioning system standard features can be deleted and/or substituted with optional features to allow you the flexibility to select the configuration best suited for your application.

### Adjustable Floor Stand

An adjustable floor stand shall be provided to allow installation of the Mini-Space EC floor-mounted air conditioning system onto a raised floor environment. Floor stand height shall be adjustable. The floor stand shall ship separately for field installation.

### Top Discharge Plenum Box (Up-flow units only)

A 2- or 3-way plenum discharge box shall be provided. The plenum box shall include double-deflecting, adjustable grilles. The plenum box shall ship separately for rigging purposes.

### Condensate Pump

A condensate pump for automatic removal of condensate and humidifier flush water (if applicable) shall be shipped loose for field installation in the Mini-Space EC floor-mounted air conditioning system. The condensate pump shall include an internal overflow safety float which, when wired to the Mini-Space EC unit's remote stop/start terminals, shall open the unit's control circuit, thereby shutting the unit down in the event of a condensate overflow. The condensate pump shall be specifically designed to operate with the higher condensate temperatures caused by the flush and drain cycle of the electrode canister humidifier.

### Smoke Detection

A photo-electric smoke detector shall be factory installed and wired in the return air section of the Mini-Space EC floor-mounted air conditioning system. The photo-electric detector shall include built-in circuitry that performs a functional test of all detection circuits at least once every 40 seconds without the need for generating smoke. The UL listed velocity range shall be 0-3000 fpm. The air conditioner will shut down upon sensing smoke in the return air stream.

### Firestat

The Mini-Space EC floor-mounted air conditioning system shall be provided with a factory wired and mounted firestat. The firestat will shut down the air conditioner upon sensing a high return air temperature.

### Remote Water Detector- Spot Type

A remote single point water/leak detector shall be factory supplied and shall ship separately for field installation. Upon sensing a water leak, the normally closed water detector control circuit shall open, thereby shutting down the Mini-Space EC floor-mounted air conditioning unit's water producing components.

### **Remote Water Detector- Strip Type**

A 20 ft in length remote strip/cable type water/leak detector shall be provided for remote field installation. In addition to the 20 ft sensing cable, a 24 volt water detector power module shall require field mounting and wiring to the factory provided terminal connection. Upon sensing a water leak, the normally closed water detector control circuit shall open, thereby shutting down the Mini-Space EC floor-mounted air conditioning unit's water producing components.

### **Low Entering Condenser Water Kit**

For Water/Glycol systems that require entering condenser water temperatures from 65 °F to 45 °F, the system shall be provided with a factory installed in-line liquid refrigerant receiver to help reduce the negative effect the low condenser source can have on the evaporator. A compressor crankcase heater shall also be provided standard with this option.

---

## **CODE CONFORMANCE**

---

Intertek Laboratory (an NRTL) listed and labeled in compliance with UL 1995 and CSA C22.2 No. 236.



# STULZ North American Headquarters

## STULZ AIR TECHNOLOGY SYSTEMS (STULZ USA), INC.

1572 Tilco Drive | Frederick, MD 21704  
Tel: 301.620.2033 | Fax: 301.662.5487 | [info@stulz-ats.com](mailto:info@stulz-ats.com)

### STULZ Company Headquarters

#### STULZ GmbH

Holsteiner Chaussee 283  
22457 Hamburg  
[products@stulz.de](mailto:products@stulz.de)

### STULZ Subsidiaries

#### STULZ Australia Pty. Ltd.

34 Bearing Road  
Seven Hills NSW 2147

#### STULZ Austria GmbH

Industriezentrum NÖ – SÜD,  
Straße 15, Objekt 77, Stg. 4, Top 7  
2355 Wiener Neudorf

#### STULZ Belgium BVBA

Tervurenlaan 34  
1040 Brussels

#### STULZ Brasil

**Ar Condicionado Ltda.**  
Rua Cançioneiro de Évora, 140  
Bairro - Santo Amaro São  
Paulo-SP, CEP 04708-010

#### STULZ España S.A.

Avenida de los Castillos 1034  
28918 Leganés (Madrid)

#### STULZ France S. A. R. L.

107, Chemin de Ronde  
78290 Croissy-sur-Seine  
[info@stulz.fr](mailto:info@stulz.fr)

#### STULZ S.p.A.

Via Torricelli, 3  
37067 Valeggio sul Mincio (VR)

#### STULZ-CHSPL (India) Pvt. Ltd.

006, Jagruti Industrial Estate  
Mogul Lane, Mahim  
Mumbai - 400016

#### STULZ México S.A. de C.V.

Avda. Santa Fe No. 170  
Oficina 2-2-08, German Centre  
Delegación Alvaro Obregon  
MX- 01210 México  
Distrito Federal

#### STULZ GROEP B. V.

Postbus 75  
180 AB Amstelveen

#### STULZ New Zealand Ltd.

Office 71, 300 Richmond Rd.  
Grey Lynn, Auckland

#### STULZ Polska SP. Z O.O.

Budynek Mistral.  
Al. Jerozolimskie 162  
02 – 342 Warszawa

#### STULZ Singapore Pte Ltd.

33 Ubi Ave 3 #03-38 Vertex  
Singapore 408868  
[andrew.peh@stulz.sg](mailto:andrew.peh@stulz.sg)

#### STULZ Air Technology and Services Shanghai Co., Ltd.

Room 406, Building 5  
457 North Shanxi Road  
Shanghai 200040

#### STULZ South Africa Pty. Ltd.

Unit 3, Jan Smuts Business Park  
Jet Park, Boksburg  
Gauteng, South Africa

#### STULZ U. K. Ltd.

First Quarter,  
Blenheim Rd. Epsom  
Surrey KT 19 9 QN

[www.stulz-usa.com](http://www.stulz-usa.com)